

External wall grille

KWO - YGC

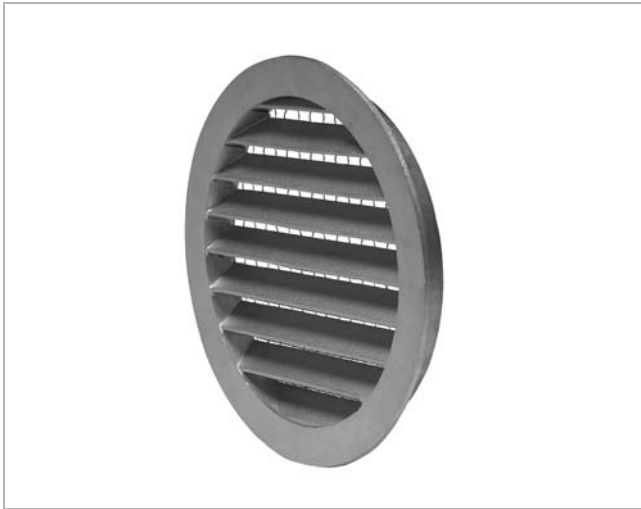

Description

Valve for outdoor air intake and extract air discharge. Designed with a fixed louvre. Ø 100–500 is equipped with net. Ø 630–1250 can be delivered with net to order. Mesh width 10×10 mm. Screws or nails connect to an external wall.

Maintenance

The grille should be removed to gain access to the duct. The external parts should be wiped with a damp cloth.

Dimensions

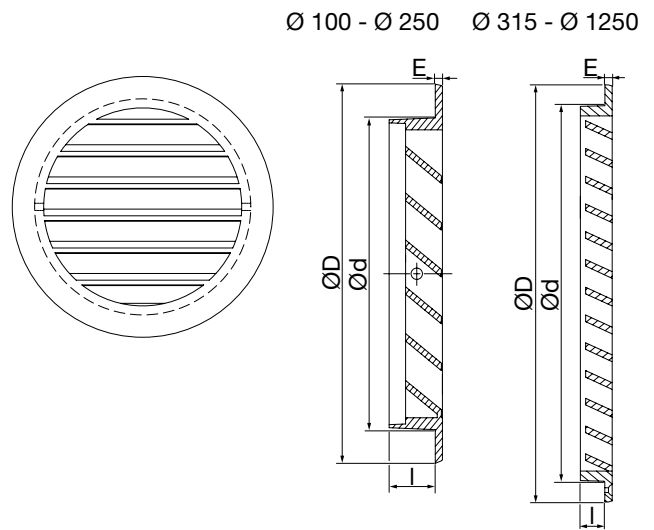

Ød nom	ØD mm	l mm	E mm	A _f (m ²)	Weight kg
100*	131	22,0	3,5	0,004	0,17
125*	151	22,5	3,5	0,007	0,25
160*	188	21,5	3,5	0,012	0,39
200*	230	21,5	3,5	0,020	0,51
250*	278	24,5	3,5	0,031	0,83
315**	350	15,5	6,5	0,047	1,81
400	430	34,0	6,5	0,075	3,00
500	530	34,0	6,5	0,118	5,50
630	660	50,5	1,5	0,187	8,80
800	830	50,5	1,5	0,300	14,6
1000	1030	50,5	1,5	0,470	21,0
1250	1280	50,5	1,5	0,740	35,0

* The grill has 2 x Ø 4,2 mm screw holes on the side for mounting.

** The grill has 3 x Ø4,0 mm screw holes on the front for mounting.

Ød > 315 mm , no pre-drilled holes for mounting.

A_f (m²) = Free area.

Materials and finish

Grille: ø100-500 Cast aluminium...KWO-AL
 Grille: ø630-1,250 (80) Galvanisedsteel....YGC
 Standard finish: Untreated

Can be supplied powder-coated. Contact Lindab's sales department for further information.

Order code

Product **KWO/YGC** **aaaa**
 Type _____
 Size Ød _____

External wall grille

KWO - YGC

Technical data

Capacity

Volumeflow, q [l/s] and [m³/h], total pressure drop, Δp_t [Pa], can be seen in the diagrams.

Sound level in free field (1/4 spherical)

The sound effect level L_{WA} is shown in the diagram.

For sound level at distance X [m],

$L_A = L_{WA} - K$, see table below.

X [m]	1	2	3	4	5	10	20
K [dB]	-5	-12	-15	-17	-19	-25	-30

